



# DAWSON CONTRACT PILING



Harbour



Motorway



Rail



Basement



Sustainable Foundation



Specialist Work >



## UNDERWATER PILE DRIVING

Shell Pierce C1 Development - NORTH SEA (2012)

▼ The Shell Pierce C1 Development lies some 150 miles due east of Aberdeen, 85 metres below sea level. The development will introduce a new oil production site approximately 3kms to the north west of the existing facility.

A new WHPS (wellhead protection system) was installed during May 2012 and fixed in position. The WHPS is required as the wellhead is remote from the existing facilities and therefore protection is required to prevent damage to the asset due to dropped objects and interaction from fishing gear.

As part of the offshore pile driving operations, Dawson Contract Piling supplied a complete primary & backup spread with all associated piling equipment, including a Dawson HPH15k

impact hammer. DCP also provided offshore support technicians, operators and project managers to SUBSEA 7 for the purposes of pile installation for the WHPS. Four Ø24" x 19.1m piles were successfully driven to target penetration to secure the WHPS to the sea bed.

In the offshore feed back report the client highlighted the proactive, helpful and excellent service of the Dawson team and that DCP should be considered at the engineering/tender stage for similar campaigns. All objectives were achieved and the job completed within specification and tolerance.

**Technical Specifications**

**TEC. SPEC**

The WHPS is a slab sided piled structure weighing circa 140Te which will provide protection to the C1 Tree from dropped objects and fishing interaction. The WHPS was piled by means of four Ø610mm (24") OD x 19.1m piles. The Dawson 15k hydraulic piling hammer with new electrical switching was deployed to drive these piles. Each pile was driven to level well within limits with a total hamer overboard time of 4hrs.

Geology	Depth below seabed (m)	Lithology
Holocene Sediment	0.0 - 0.5	Silty fine SAND
	0.5 - 1.0	Firm to stiff slightly sandy CLAY
Coal Pit Formation	1.0 - 38	Dense to very dense slightly silty SAND with very stiff to hard CLAY
Fisher Formation	38 - 86	Very stiff to hard sandy CLAY
Ling Bank Formation	86 - 100	Very stiff to very hard sandy CLAY

Summary of Soil Conditions at the structure



**SITE LOCATION**

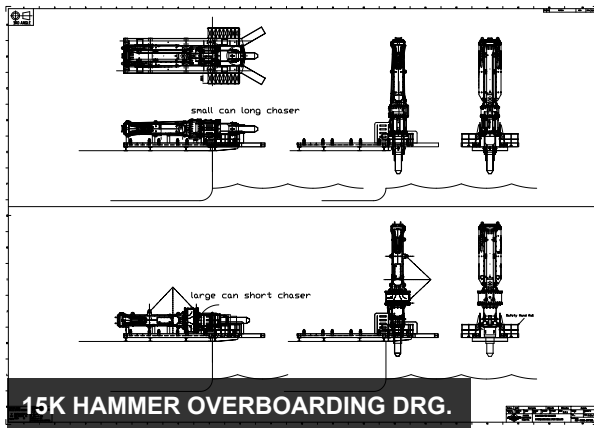

**15K HAMMER OVERBOARDING DRG.**

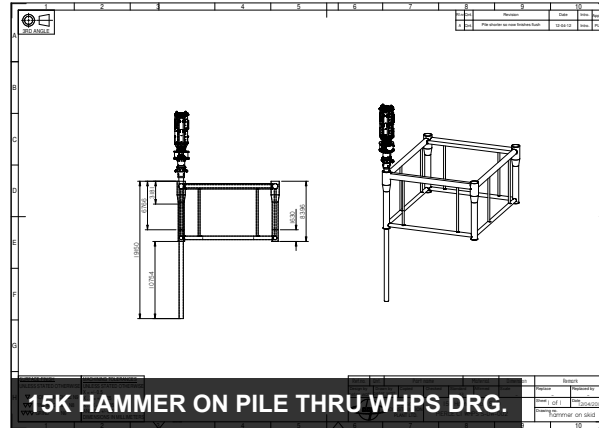

**15K HAMMER ON PILE THRU WHPS DRG.**



**15K HAMMER LOCATING ON PILE**



**WELLHEAD PROTECTION SYSTEM**



**HAMMER PERFORMANCE MONITORING**



**CONSTRUCTION VESSEL**



**DAWSON**  
CONTRACT PILING LTD

Our Expertise is your Solution

Dawson Contract Piling Ltd  
Chesney Wold,  
Bleak Hall,  
Milton Keynes,  
MK6 1NE, England  
Tel: +44 (0)1908 240300  
Fax: +44(0)1908 240222  
www.dcpuk.com